

# PASLANMAZ ÇELİK KÜRESEL VANA (DIŞLI 2 PARÇALI PN 40)

-STAINLESS STEEL BALL VALVE (THREADED 2 PCS PN 40)

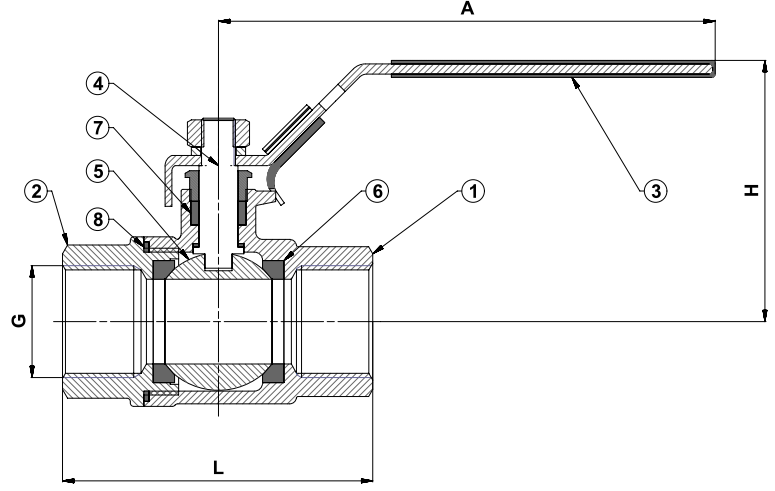

T-0630 Paslanmaz Çelik Döküm / Cast Stainless Steel



## Genel Özellikler / General Specifications

Çalışma Sıcaklık Aralığı / Working Temperature : -10... +120 °C (40 Bar)

## Standartlar / Standards

Sertifikalar / Certificates : CE P

Tasarım / Design : TS 3148, EN ISO 17292

Diş Standartı / Thread Standard : EN ISO 228-1

Testler / Tests : TS EN 12266-1

## Uygulamalar / Applications

Sıcak ve soğuk su sistemleri, kızgın su, basınçlı hava, soğutma yağı, deniz suyu  
Hot and cold water systems, superheated water, compressed air, cooling oil, sea water

No	Parça Adı / Part Name	Malzeme / Material
1	Gövde / Body	G-X6CrNi189 - CF8 - Paslanmaz Çelik / Cast Stainless Steel
2	Kapak / Bonnet	G-X6CrNi189 - CF8 - Paslanmaz Çelik / Cast Stainless Steel
3	Kol / Lever	X5CrNi18 10 - AISI304 - Paslanmaz Çelik / Stainless Steel
4	Mil / Stem	X5CrNi18 10 - AISI304 - Paslanmaz Çelik / Stainless Steel
5	Küre / Ball	G-X6CrNiMo18 10 - CF8M - Paslanmaz Çelik / Cast Stainless Steel
6	Ringler / Seals	PTFE - Teflon
7	Salmastra / Packing	PTFE - Teflon
8	Conta / Gasket	PTFE - Teflon

Ölçüler / Dimensions	Anma Basıncı / Nominal Pressure	40 Bar						
	Anma Çapı / Nominal Diameter	DN	15	20	25	32	40	50
	Vana Boyutları / Valve Dimensions	G	1 / 2"	3 / 4"	1"	1 1 / 4"	1 1 / 2"	2"
		L	75	80	90	110	120	140
		H	52	61	65	79	83	97
A		103	123		153		185	
Ağırlık / Weight	Kg.	0.2	0.5	0.8	1.1	1.8	3	